

GATE ELEVATION – (5) BAYS SHOWN

SEE SHEET #2 FOR SECTIONS AND DETAILS

NOTES:

1. FOOTING WIDTH TO BE (4)X POST WIDTH. MIN DEPTH TO BE 36".
2. GATES MAY BE MANUALLY OR ELECTRICALLY OPERATED.

NOM HEIGHT (H)
6'-0"
7'-0"
8'-0"
10'-0"
12'-0"
OPENING
6'-0" THROUGH 50'-0"

MASTER HALCO, INC.
 PHONE 888-643-3623
 WWW.MASTERHALCO.COM

TWIN-TRAC® CANTILEVERED SLIDING GATE
 ROUND POSTS, W/O BARBED WIRE

BY:	TPA	DWG:
DATE:	01-03-08	
REV BY:		LAYER: 1
REV DATE:		SCALE: NTS

OPENING	LENGTH (L)	GATE POSTS (G)
I/S POST FACE TO I/S POST FACE	O/S DIM OF GATE LEAF	O/S POST FACE TO O/S POST FACE
31'-0"	44'-0"	13'-0"
32'-0"	45'-6"	13'-0"
33'-0"	47'-0"	13'-6"
34'-0"	48'-0"	14'-0"
35'-0"	49'-6"	14'-0"
36'-0"	51'-0"	15'-0"
37'-0"	52'-6"	15'-6"
38'-0"	54'-0"	15'-6"
39'-0"	55'-6"	16'-0"
40'-0"	56'-6"	16'-0"
41'-0"	58'-0"	16'-6"
42'-0"	59'-6"	17'-0"
43'-0"	60'-6"	17'-0"
44'-0"	62'-0"	17'-6"
45'-0"	63'-6"	18'-0"
46'-0"	65'-0"	18'-6"
47'-0"	66'-6"	19'-0"
48'-0"	67'-6"	19'-0"
49'-0"	69'-0"	19'-6"
50'-0"	70'-6"	20'-0"

ONE PIECE EXTRUDED ALUMINUM
TOP TRACK/FRAME MEMBER
7.95 LBS/FT.

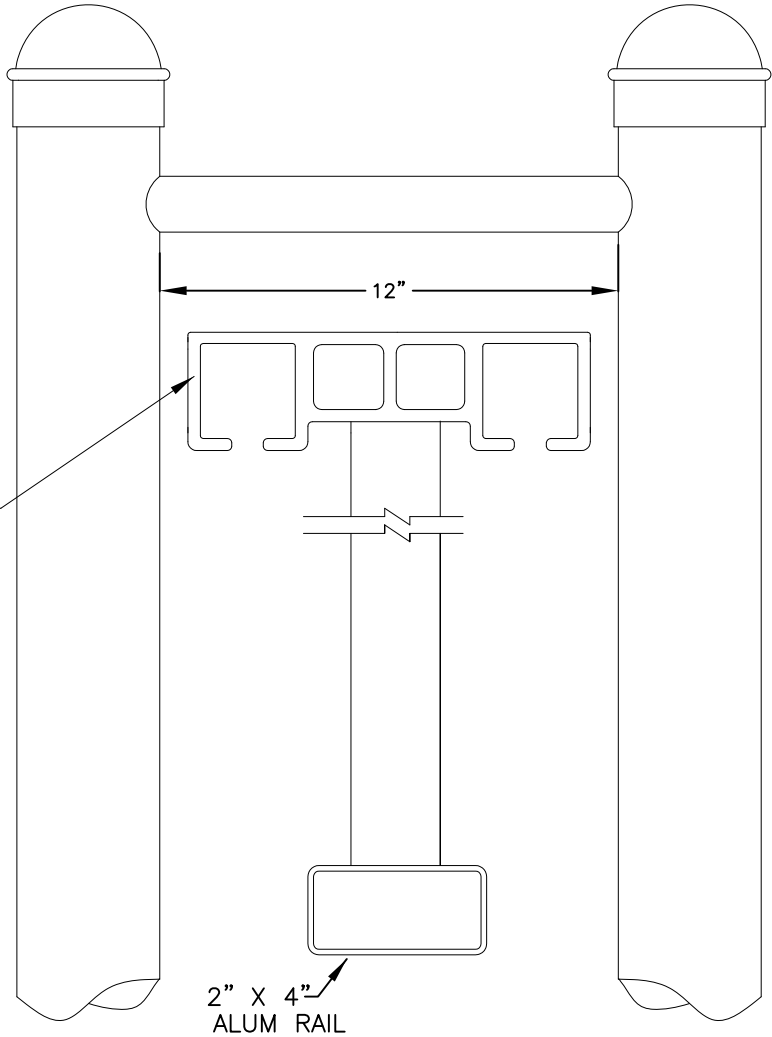

SEC A (31' THRU 50' OPENINGS)

SEE SHEET #1
FOR ELEV & PLAN

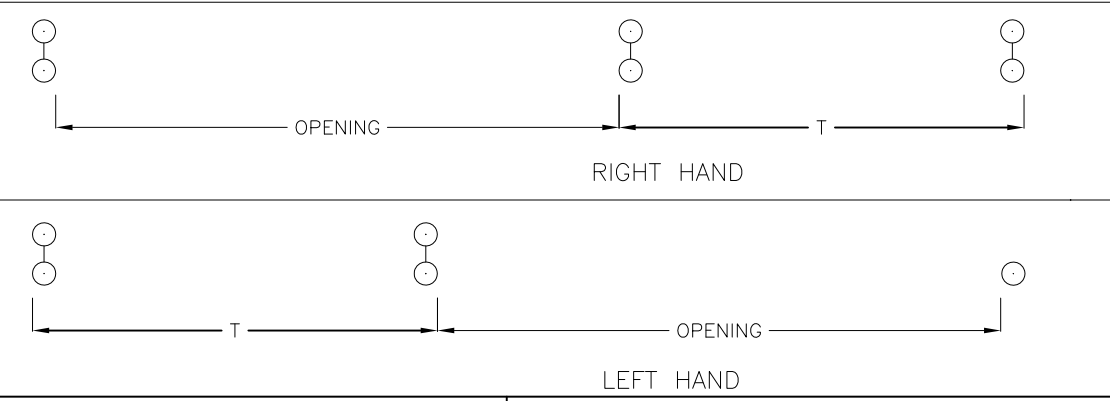

MASTER HALCO, INC.
PHONE 888-643-3623
WWW.MASTERHALCO.COM

TWIN-TRAC® CANTILEVERED SLIDING GATE
SIZING CHART

BY:	CAN	DWG:
DATE:	10-22-13	
REV BY:		LAYER: 1
REV DATE:		SCALE: NTS

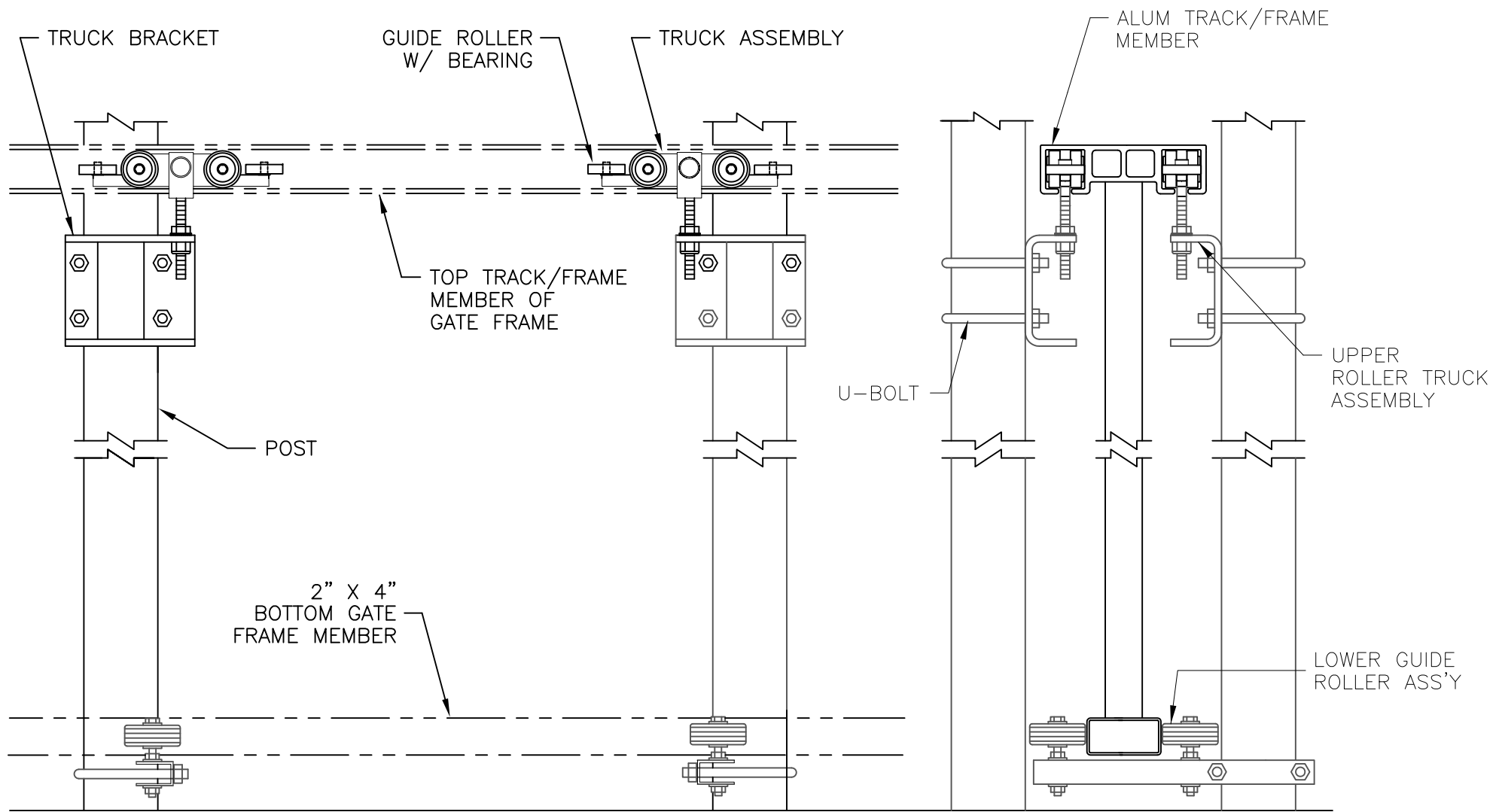

ELEVATION

END VIEW

NOTE: TRUCK BRACKET AND BOTTOM GUIDE ROLLER ASS'Y CAN ALSO BE BOLTED TO A SOLID GROUTED CMU WALL.



MASTER HALCO, INC.
 PHONE 888-643-3623
 WWW.MASTERHALCO.COM

TWIN-TRAC® CANTILEVERED SLIDING GATE
 TRUCK AND ROLLER DETAILS

BY:	TPA	DWG:
DATE:	01-03-08	
REV BY:		LAYER: 1
REV DATE:		SCALE: NTS

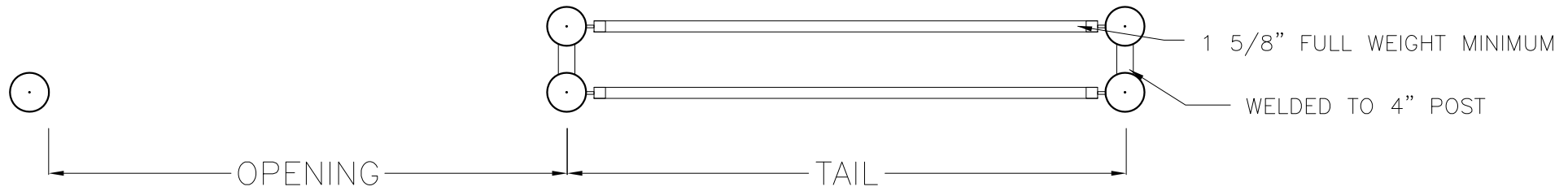

NOTE.
ALL POSTS ARE TO BE PLUM AND
LEVEL AT TOP.

